

Mida

STORAGE UNITS

2003

Antonio Citterio



Description

The common denominator in Mida storage units is a base-frame of steel profiles which supports various typologies of storage units: the smallest with feet are available in two heights, doors that rotate outwards 270° and different internal equipment; the low and long sideboard with rotating doors reveals either the two external compartments or the central compartments. Different types of wood available including a cut that reproduces the manual craftsmanship of sawn edges, leaves traces of processing that add value to its timeless elegance, a distinguishing feature for Maxalto. The internal frame of storage units are in wood or glossy finish.

Technical information

Frame

solid wood, wood particles panel, plywood panel with honeycomb-core and wood particles, veneered multi-layered wood panel

Base-frame

steel profiles

Adjustable feet

steel and plastic material

Technical drawings

ACAN1

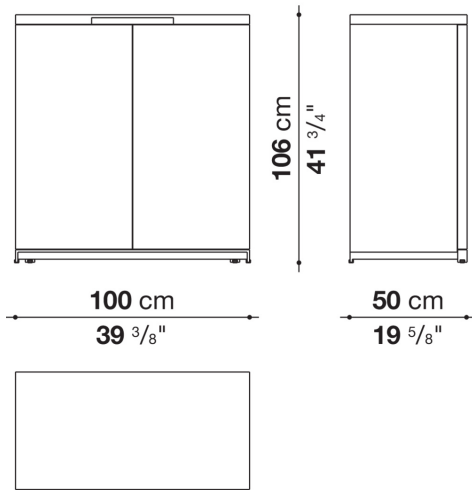

ACAN2

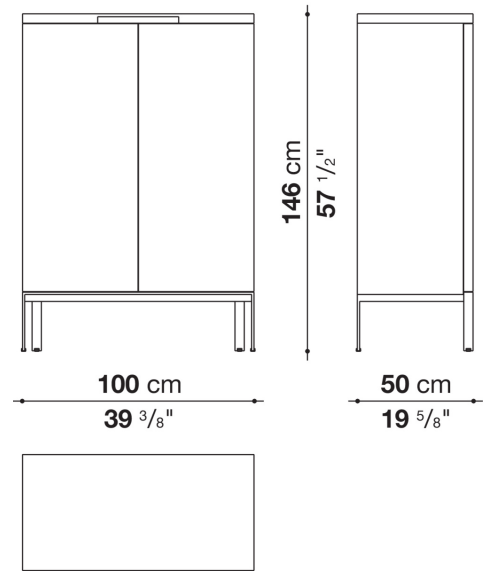

ACAN3

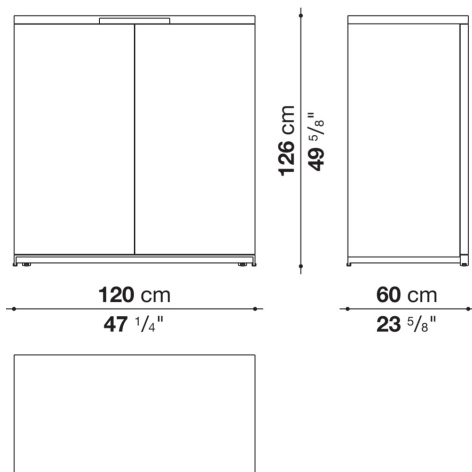

ACAN4

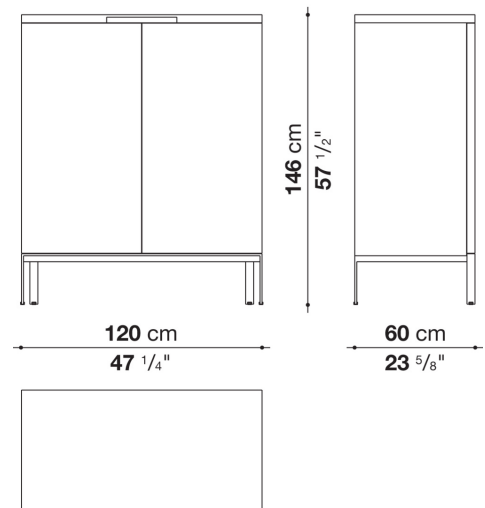

ACCR1

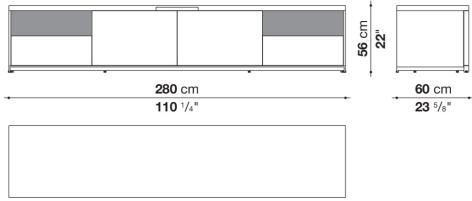

ACAN1M

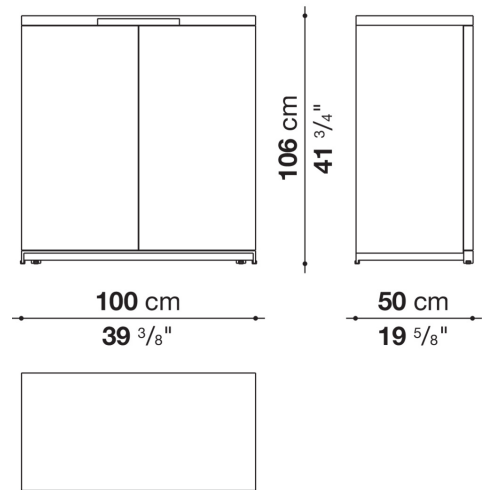

ACAN2M

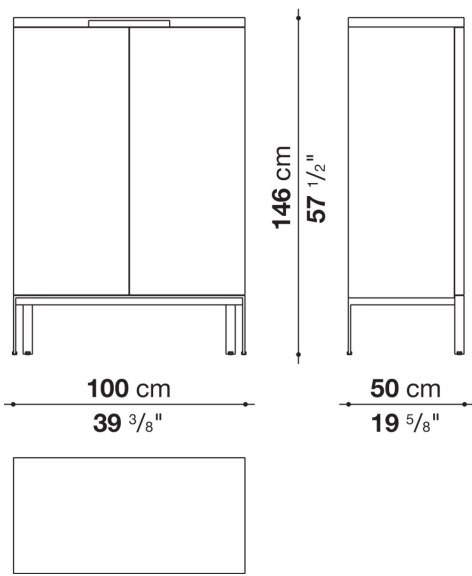

ACAN3M

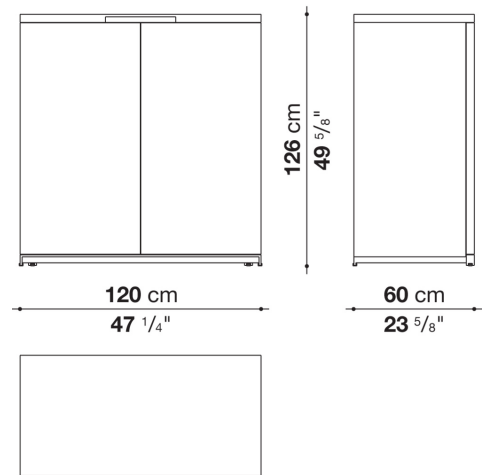

ACAN4M

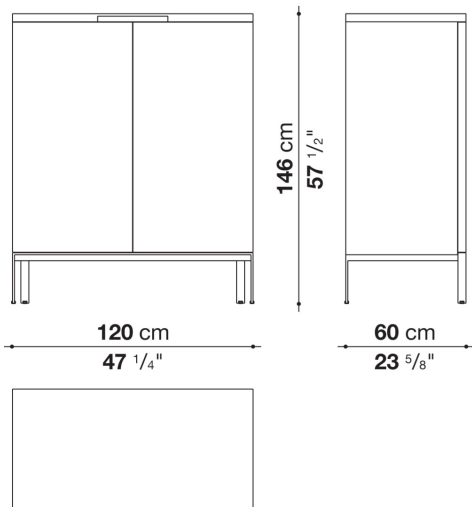

ACCR1M

